

# PINION YOKE - with Outside Locating Tabs

For use with standard **OUTSIDE LOCK - U-Joints**

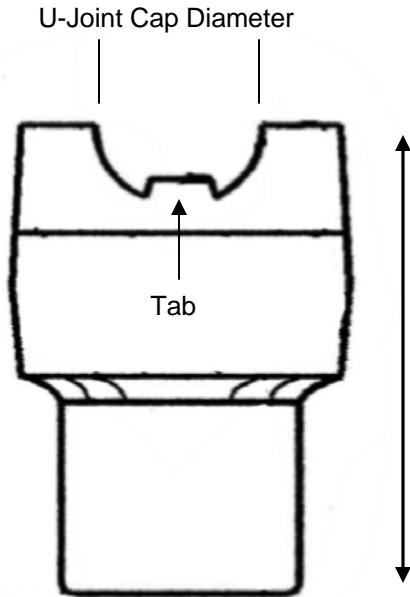

\_\_\_\_\_ UJ Cap Diameter

\_\_\_\_\_ UJ Width

\_\_\_\_\_ Overall Height

\_\_\_\_\_ Spline Count

\_\_\_\_\_ Spline width - this needs to be done with a dial or digital caliper as accuracy is very important.

\_\_\_\_\_ Ground Hub diameter - this is the diameter of where the seal rides. This should be done with a caliper.

\_\_\_\_\_ Length thru the hole. Very important. This is not shown but is simply the total depth of hole thru the center of yoke

Measure UJ width from inside edges of tabs - where the UJ will actually fit

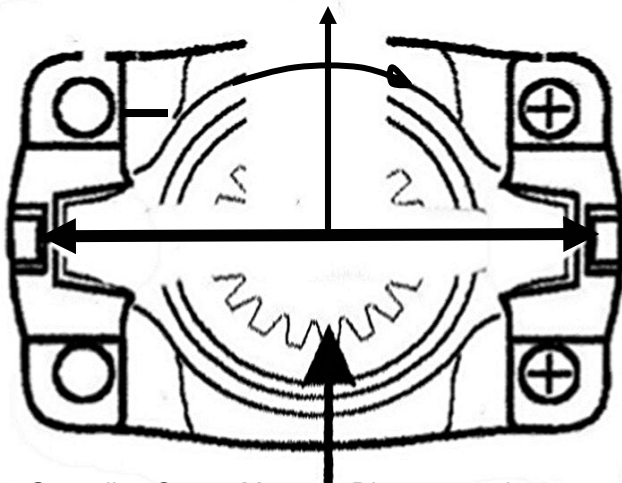

Differential Type \_\_\_\_\_

Name \_\_\_\_\_

Address \_\_\_\_\_

City/ST/Zip \_\_\_\_\_

Phone \_\_\_\_\_

Email or Fax \_\_\_\_\_

Notes \_\_\_\_\_

Get spline Count- Measure Diameter at deepest point across to exact other side at deepest point.

**Fill out form fields. Save a copy of form and email form to [sales.dsi@sbcglobal.net](mailto:sales.dsi@sbcglobal.net) OR Fax to 210.342.7074**

**DRIVESHAFT SPECIALIST, INC.**

**8327 McCullough Ave San Antonio, TX 78216**

**PHONE: 210-342-6622 FAX: 210-342-7074 TOLL FREE: 866-455-6622**

**email is [sales.dsi@sbcglobal.net](mailto:sales.dsi@sbcglobal.net)**

**[www.driveshaftspecialist.com](http://www.driveshaftspecialist.com)**