

# PINION YOKE - No Locating Tabs

For use with INSIDE LOCK - C Clip U-Joints

U-Joint Cap Diameter

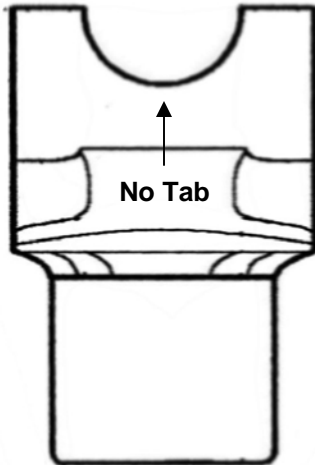

\_\_\_\_\_ UJ Cap Diameter

\_\_\_\_\_ UJ Lock up Width

\_\_\_\_\_ Overall Height

\_\_\_\_\_ Spline Count

\_\_\_\_\_ Spline width - this needs to be done with a dial or digital caliper as accuracy is very important.

\_\_\_\_\_ Ground Hub diameter - this is the diameter of where the seal rides. This should be done with a caliper.

\_\_\_\_\_ Length thru the hole. Very important. This is not shown but is simply the total depth of hole thru the center of yoke

Inside Lock up Width - This type yoke uses the C-Clips on the UJ cap to lock the UJ into place. C-Clips must be used on this type of yoke or the UJ caps will come out.

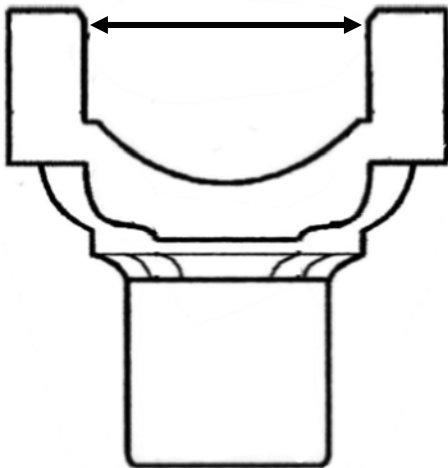

This is the inside lock UJ. All 4 clips are to be used - 2 are left off in this photo so clips can be seen. These clips lock the UJ in place on the inner edges of pinion yoke shown by the arrows on the left.



Name \_\_\_\_\_

Phone \_\_\_\_\_

Email \_\_\_\_\_

DRIVESHAFT SPECIALIST, INC. 8327 McCullough, SAN ANTONIO, TX 78216

PHONE: 210-342-6622 FAX: 210-342-7074 TOLL FREE: 866-455-6622

www.driveshaftspecialist.com -- Copyright © 2009